

## 4-Cylinder, Low-Pressure Diaphragm Pumps

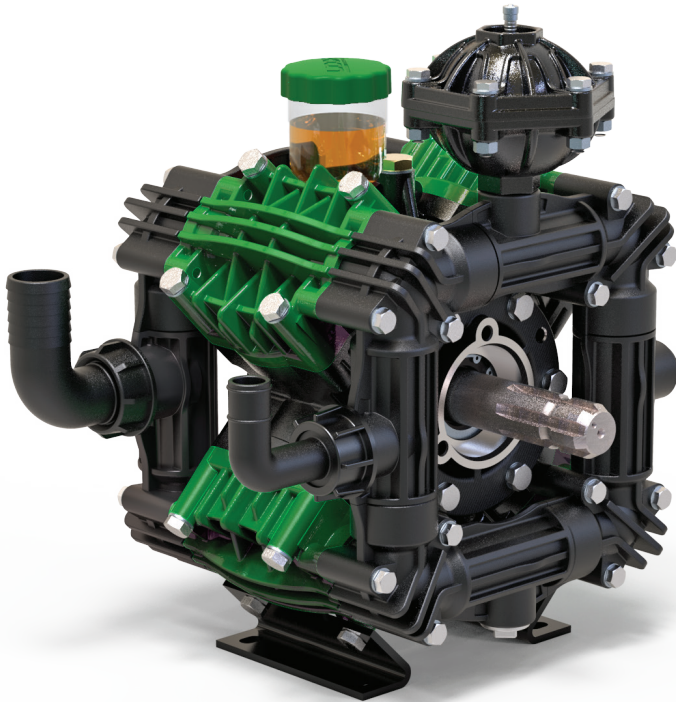

ZETA 170 low pressure 4-cylinder diaphragm pumps have anodized aluminum bodies with plasticized aluminum heads, stainless steel valves and glass-filled nylon manifolds. A pulsation dampener standard on all models.

ZETA 170 pumps are excellent for various horticultural and agricultural spraying applications.

Pumps are available with a 1-3/8" Male PTO shaft, 1-3/8" Male PTO thru-shaft or 2-bolt A-flange hydraulic motor mount with 1" hollow shaft.

Model	GPM	l/min	PSI	bar	RPM	Drive Configuration	Weight
ZETA 170 1C	45.0	170	300	20	550	1-3/8" 6-Spline Male PTO Shaft	58 LBS
ZETA 170 TS2C	45.0	170	300	20	550	1-3/8" 6-Spline Male PTO Thru-Shaft	58 LBS
ZETA 170 MI1	45.0	170	300	20	550	2-Bolt, A-Flange, 1" Hollow Shaft for Hydraulic Motor	58 LBS

Specifications	ZETA 170	Description	Part #
Inlet Port	1-1/2" Hose Barb	Diaphragm Kit (GREENTECH)	6062.H3
Outlet Port	1" Hose Barb	Diaphragm Bolt & Washer Kit	6062.24
Piston Diameter	75.0mm	Valve Kit	6062.D5
Crankshaft Stroke/Code	18.0mm / E	Complete Repair Kit	8700.09CK
Dimensions	15.5"L x 12.5"W x 17.5"H		

**Lubrication:** Requires 44 oz. of Udor Lube 40W Premium Pump Oil.  
Alternate Oil: 30W non-detergent or 15W-40 non-detergent oil.



Maximum Flow	45.0 GPM / 170 lpm
Maximum Pressure	300 PSI / 20 bar
Maximum RPM	550 RPM
Inlet Port - Hose Barb	1-1/2" HB
Outlet Port - Hose Barb	1" HB
Bypass - Hose Barb	-
Dimensions	15.5"L x 12.5"W x 17.5"H
Weight	58 lbs

**Lubrication:** Requires 44 oz. of Udor Lube 40W Premium Pump Oil.  
 Alternate Oil: 30W non-detergent or 15W-40 non-detergent oil.

606224 KIT 523		6062D5 KIT 638		6062H3 KIT 671		8700.09CK	
CODE	QTY	CODE	QTY	CODE	QTY	CODE	QTY
010201	4	110101	8	090314	1	010201	4
030107	4	600677	8	090361	4	030107	4
				110101	8	090314	4
				110102	1	110101	8
				110142	1	110102	1
				600677	8	110142	1
						600677	8

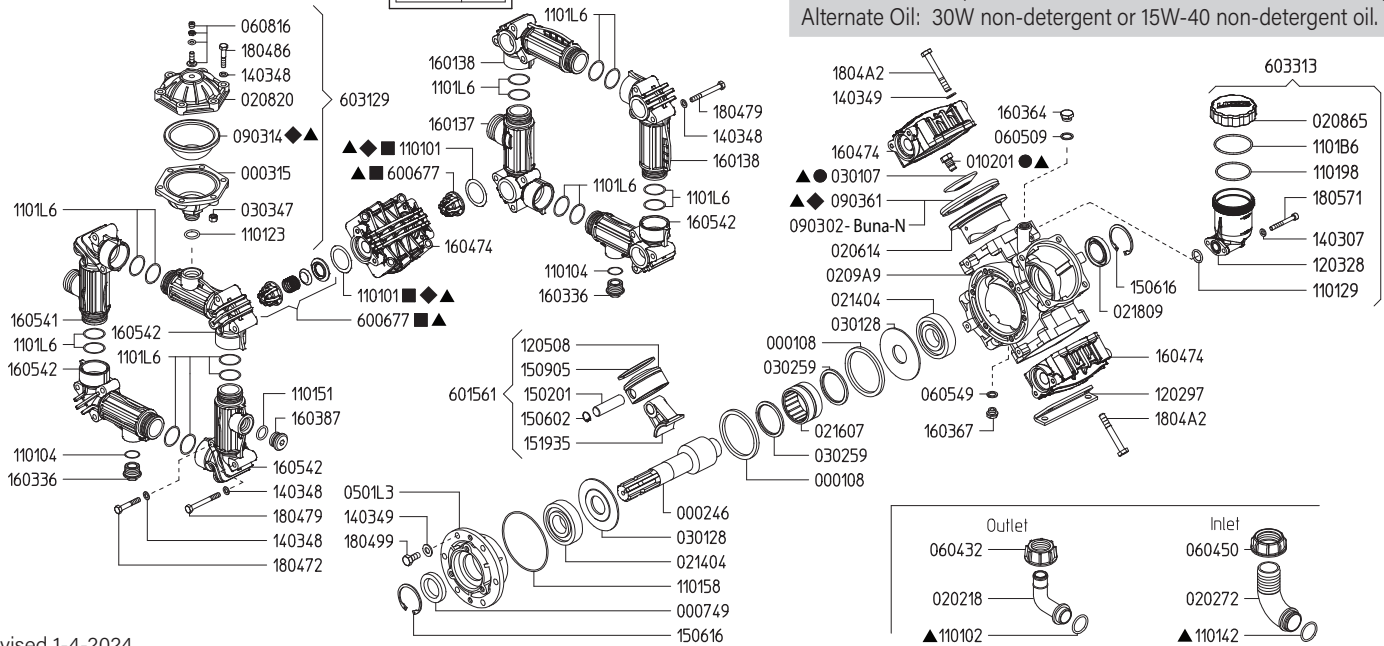

Revised 1-4-2024

Part #	Description	Qty	Part #	Description	Qty
0001.08	RETAINER RING	1	1202.97	RAIL	2
0002.46	CRANKSHAFT	1	1203.28	OIL RESERVIOR	1
0003.15	ACCUMULATOR BASE	1	1205.08	ALUMINIUM PISTON D75	4
0007.49	OIL SEAL D35	1	1403.07	WASHER M6	2
0102.01	DIAPHRAGM BOLT ●▲	4	1403.48	WASHER M8	30
0202.18	HOSE BARB D25	1	1403.49	WASHER M10	18
0202.72	HOSE BARB D40	1	1502.01	PIN D18X64	4
0206.14	SLEEVE D75	4	1506.02	SNAP RING D18	4
0208.20	ACCUMULATOR COVER	1	1506.16	SNAP RING D55	2
0208.65	OIL RESERVIOR CAP	1	1509.05	PISTON RING D75	4
0209.A9	CRANKCASE	1	1519.35	CONNECTING ROD	4
0214.04	BALL BEARING D35	2	1601.37	SUCTION MANIFOLD G1"1/2 M	1
0216.07	ROLLER BEARING D55	1	1601.38	INLET-OUTLET MANIFOLD	2
0218.09	CAP D55X10	1	1603.36	PLUG G3/4	2
0301.07	DIAPHRAGM WASHER ●▲	4	1603.64	PLUG G3/8	1
0301.28	ROD DISC D35	2	1603.67	PLUG G1/4	1
0302.59	ROD DISC	2	1603.87	PLUG G3/4	1
0303.47	HEX NUT M8X8	6	1604.74	HEAD	4
0501.L3	BEARING FLANGE	1	1605.41	OUTLET MANIFOLD G1"1/4 M	1
0604.32	BARB NUT G1"1/4	1	1605.42	INLET-OUTLET MANIFOLD G3/4 F	4
0604.50	BARB NUT G1-1/2"	1	1804.72	HEX BOLT M8X50	8
0605.09	GASKET D17	1	1804.79	HEX BOLT M8X70	16
0605.49	GASKET D13	1	1804.86	HEX BOLT M8X40	6
0608.16	AIR VALVE ASSEMBLY	1	1804.99	HEX BOLT M10X25	6
0903.02	PISTON DIAPHRAGM - BUNA-N 116MM	4	1804.A2	HEX BOLT M10X75	16
0903.14	ACCUMULATOR DIAPHRAGM ◆◆	1	1805.71	ALLEN BOLT M6X50	2
0903.61	PISTON DIAPHRAGM - GREENTECH 116MM ◆◆▲	4	6006.77	VALVE ASSEMBLY W/O O-RING ■▲	8
1101.01	O-RING - VALVE ◆◆◆	8	6015.61	ROD ASSEMBLY D75 PISTON	4
1101.02	O-RING - DISCHARGE BARB▲	1	6031.29	PRESSURE ACCUMULATOR ASSEMBLY	1
1101.04	O-RING - DRAIN PLUG	2	6033.13	OIL RESERVIOR ASSEMBLY	1
1101.23	O-RING - PRESSURE ACCUMULATOR	1	6062.24	DIAPHRAGM BOLT & WASHER (KIT 523)	1
1101.29	O-RING - OIL RESERVIOR	1	6062.D5	IN/OUTLET VALVE KIT (KIT 638)	1
1101.42	O-RING - INLET BARB▲	1	6062.H3	DIAPHRAGM KIT - GREENTECH (KIT 671)	1
1101.51	O-RING - PLUG	1	8700.09CK	COMPLETE REPAIR KIT	1
1101.58	O-RING - BODY FLANGE	1			
1101.98	O-RING - OIL RESERVIOR	1			
1101.B6	O-RING - OIL RESERVIOR	1			
1101.L6	O-RING - MAINFOLD TUBE	16			

- Parts in 6062.24 (Kit 523).
- Parts in 6062.D5 (Kit 638).
- ◆ Parts in 6062.H3 (Kit 671).
- ▲ Parts in KIT# 8700.09CK



# ZETA 170/200 DIMENSIONS

All Dimensions are WITHOUT Control Unit or Regulator

Dimensional Drawings are Shown in Millimeters. To Convert to Inches, Multiply Dimension x 0.03937

Specifications	ZETA 170	ZETA 200
Inlet Port - Hose Barb	1-1/2" HB	2" HB
Outlet Ports - Hose Barb	1" HB	1" HB
Dimensions - Pump Only	15.5"L x 12.5"W x 17.5"H	
Diaphragm Material	GREENTECH (Std) Buna-N (Opt)	

**Lubrication:** Requires 39 oz. of Udor Lube 40W Premium Pump Oil. Alternate Oil: 30W non-detergent or 15W-40 non-detergent oil.

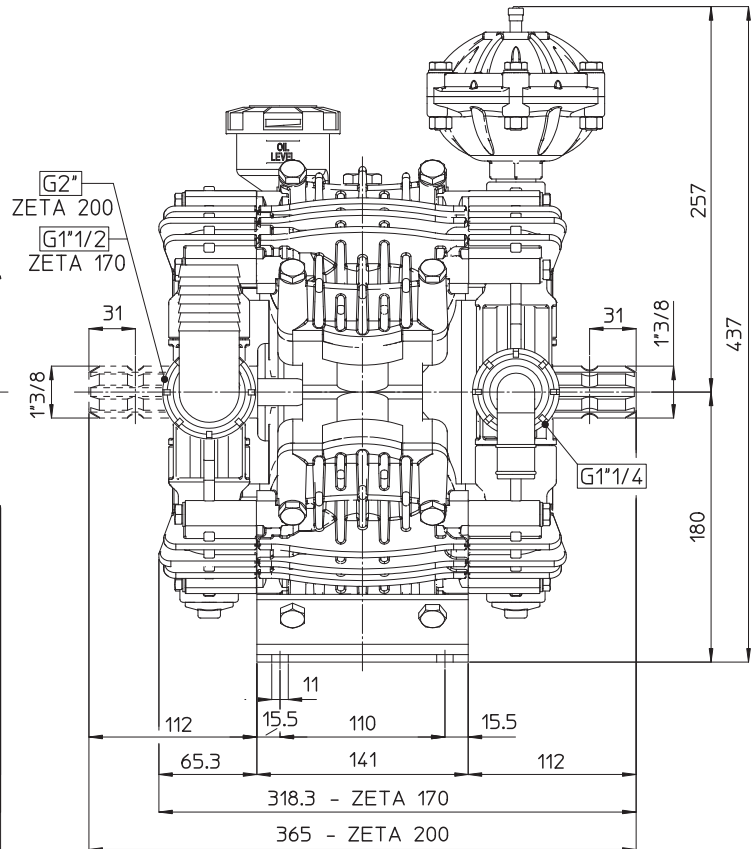
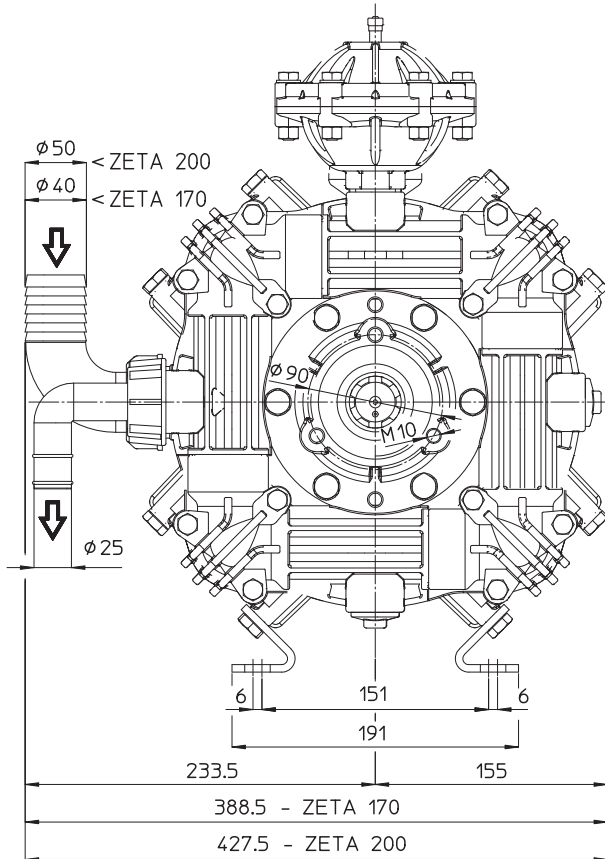

## TORQUE SPECS

Ref.	Description	Ft./lb.	Nm
1	Diaphragm Bolts (Use Loctite 243)	22	30
2	Head Bolts	30	40
3	Pulsation Dampener Bolts	18	25
4	Oil Cup Bolts	6	8
5	Manifold Bolts (Plastic)	14	20
NS	Bearing Flange Bolts (not shown)	25	34

