

M73

- 3 membrane semidrauliche, collettori interni, parti a contatto coi liquidi ossidate anticorrosione, comando incorporato o a distanza.
- 3 diaphragms semi-hydraulic, internal manifolds, all parts in contact with liquids are anodized anti-corrosion, control assembly incorporated or remote.
- 3 membranas semihidráulicas, colectores internos, partes en contacto con líquidos anodizadas anticorrosión, mando incorporado o a distancia.
- 3 membranes semi-hydrauliques, clavatures dans le carter, parties en contact avec le liquide anodisées, groupe de commande incorporé ou à distance.
- Pumpe in Sternbauweise mit 3 Kolben-Membranen halb-hydraulisch gestützt. Integrierte Saug-Druckkanäle, Kontrollventil angeflanscht oder Fernbedienung. Flüssigkeitsführende Teile rostbeständig anodiert.



IMPIEGHI

Irrorazione, atomizzatori.

APPLICATIONS

Spraying, mistblowers.

APLICACIONES

Pulverización, atomizadores.

EMPLOIS

Pulvérisation, atomiseurs.

VERWENDUNGEN

Spritzen, Sprühgeräte.

COMPONENTI	MATERIALI	COMPONENTS	MATERIALS	COMPONENTES	MATERIALES	COMPOSANTS	MATERIAUX	TEILE	MATERIALEN
carter	^ alluminio anodizzato	pump body	^ anodized aluminium	cuerpo bomba	^ aluminio anodizado	carter	^ aluminium anodisé	Gehäuse	^ anodiert Aluminium
testata	^ alluminio anodizzato	pump head	^ anodized aluminium	culata	^ aluminio anodizado	culasse	^ aluminium anodisé	Zylinderkopf	^ anodiert Aluminium
collettori	^ alluminio anodizzato	manifolds	^ anodized aluminium	colectores	^ aluminio anodizado	clavatures	^ aluminium anodisé	Saug-Druckkanälen	^ anodiert Aluminium
valvola a.-m.	acciaio inox	check valve	stainless steel	válvula a.-m.	acero inox	clapet asp. ref.	acier inox	Ventil	rostfreier Stahl
cappellotto valvola	resina sintetica	valve cage	synthetic resin	cajera válvula	resina sintética	cage du clapet	resine synthétique	Ventilkäfig	Kunstharz
membrana	* gomma nitrilica	pump diaphragm	* nitril rubber	membrana	* goma nitrilica	membrane	* caoutchouc nitrilique	Membrane	* Gummi
camera aria	gomma nitrilica	dumper diaphragm	nitril rubber	membrana calderin	goma nitrilica	chambre à air	caoutchouc nitrilique	Windkesselmembrane	Gummi
albero	acciaio cement. e temperato	pump shaft	casehardened steel	cigüeñal	acero cement. y templado	vilebrequin	acier cementé et trempé	Kurbelwelle	gehärteter Stahl

* OPTIONAL DESMOPAN

* OPTIONAL DESMOPAN

* OPTIONAL DESMOPAN

* OPTIONAL DESMOPAN

* OPTIONAL DESMOPAN

^ OPTIONAL CATAFORESI

^ OPTIONAL CATAPHORESIS

^ OPTIONAL CATAFORESI

^ OPTIONAL CATAPHORÉSE

^ OPTIONAL KATAPHORESE

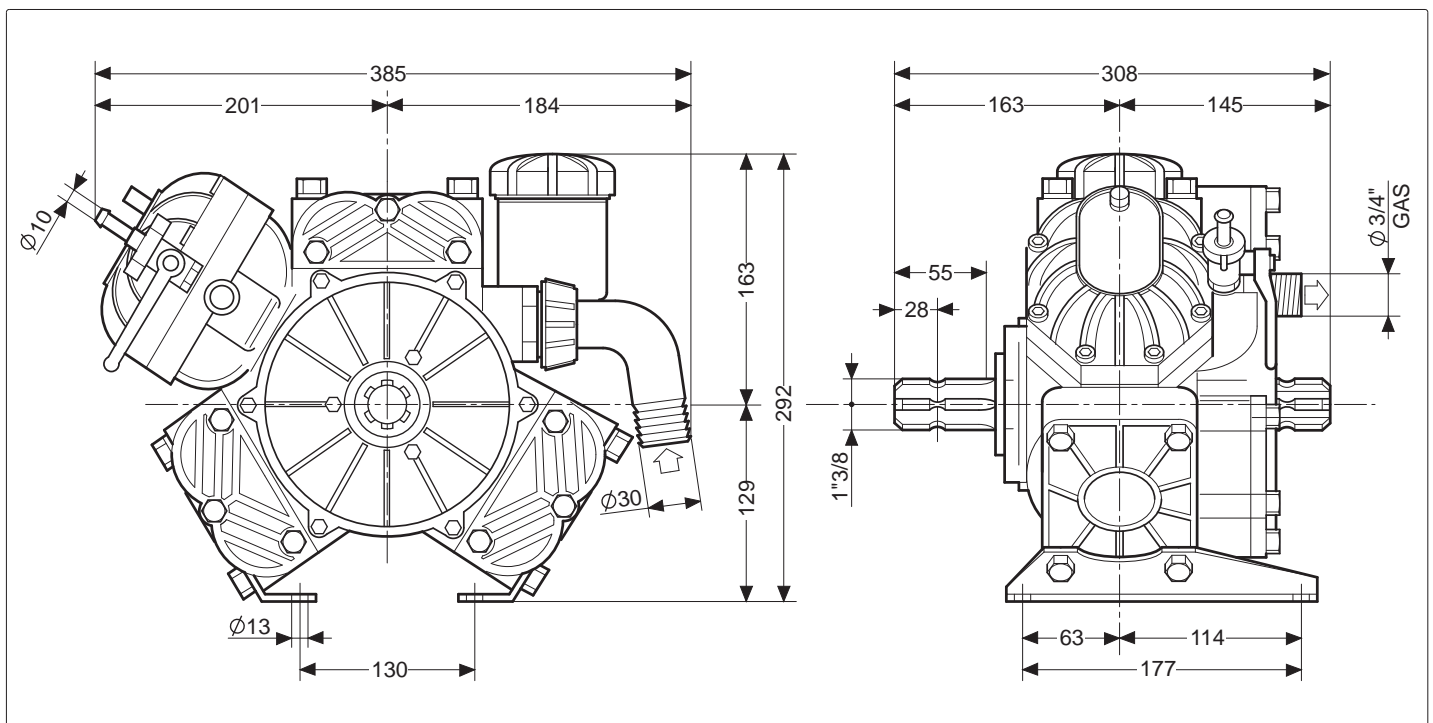

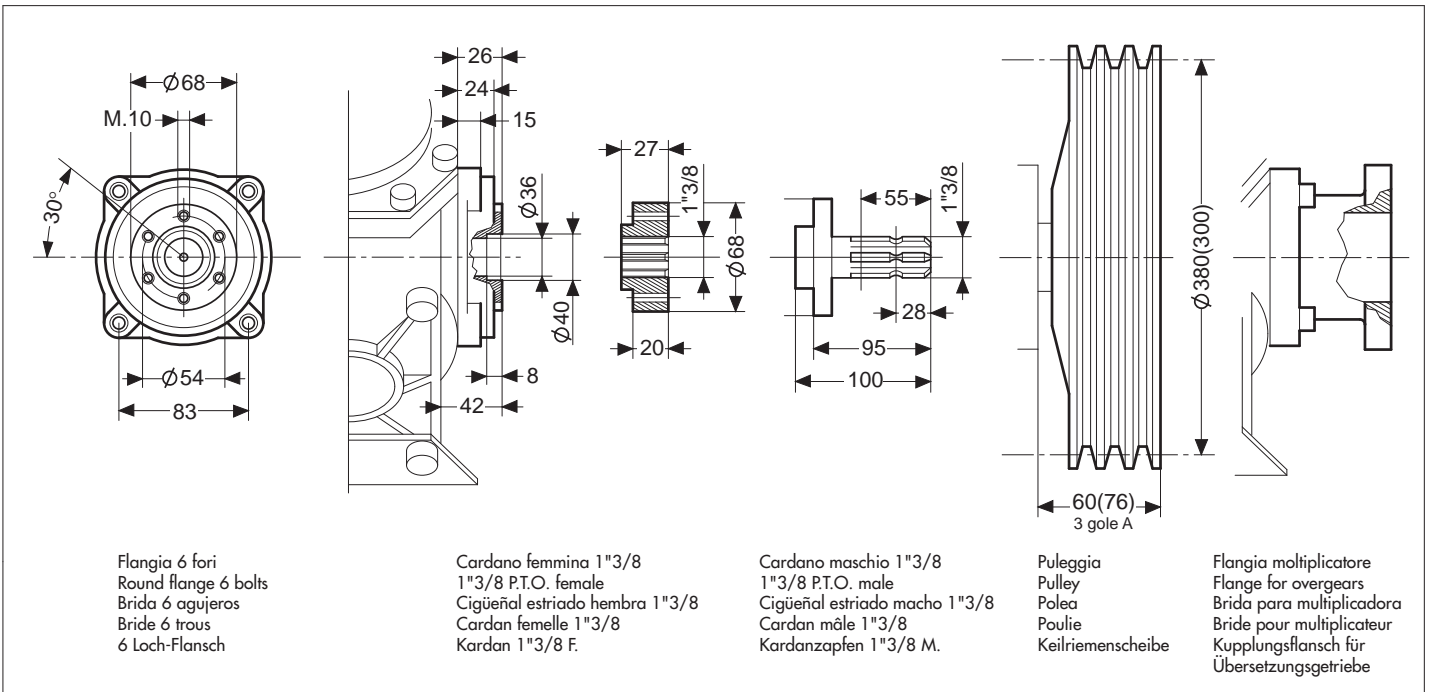

VERSIONI

Albero passante M. 1"3/8 -
M. 1"3/8, a richiesta M. 1"3/8 -
flangia 6 fori, motopompe.
Riduttore

VERSIONS

Through shaft M. 1"3/8 -
M. 1"3/8, on request through
shaft M. 1"3/8 spline - flange with
6 bolts, pump sets. Gearbox

VERSIONES

Eje pasante estriado M. 1"3/8 -
M. 1"3/8, opcional M. 1"3/8
estriado brida 6 agujeros,
motobombas. Reductora

VERSIONS

Arbre traversant cannelé mâle
1"3/8, en option traversant
cannelé mâle 1"3/8 - bride 6
trous, motopompes. Réducteur

AUSFÜHRUNGEN

Durchgehender Gelenkwellenstummel
1"3/8 - 6 teilig beiderseits, auf Wunsch
durchgehender Gelenkwellenstummel 1"3/8
- 6 Loch-Flansch, Motorpumpen.
Untersetzungsgetriebe

Giri/1': max 550
Pressione: max 50 BAR
Portata: max 70 /1'
Peso: kg 18
Max. disl. asp.: mt 3

Max RPM: 550
Pressure: max 50 BAR
Capacity: max 70 /1'
Weight: kg 18
Max suction lift: mt 3

RPM max: 550
Presión: max 50 BAR
Caudal: max 70 /1'
Peso: kg 18
Max disn. asp.: mt 3

Tours/1' max: 550
Pression: max 50 BAR
Débit: max 70 /1'
Poids: kg 18
Max haut, asp.: mt 3

Umdr. pro Minute: max 550
Druck: max 50 BAR
Förderstrom: max 70 /1'
Gewicht: kg 18
Max Ansaughöhe: mt 3

USG LT/1'

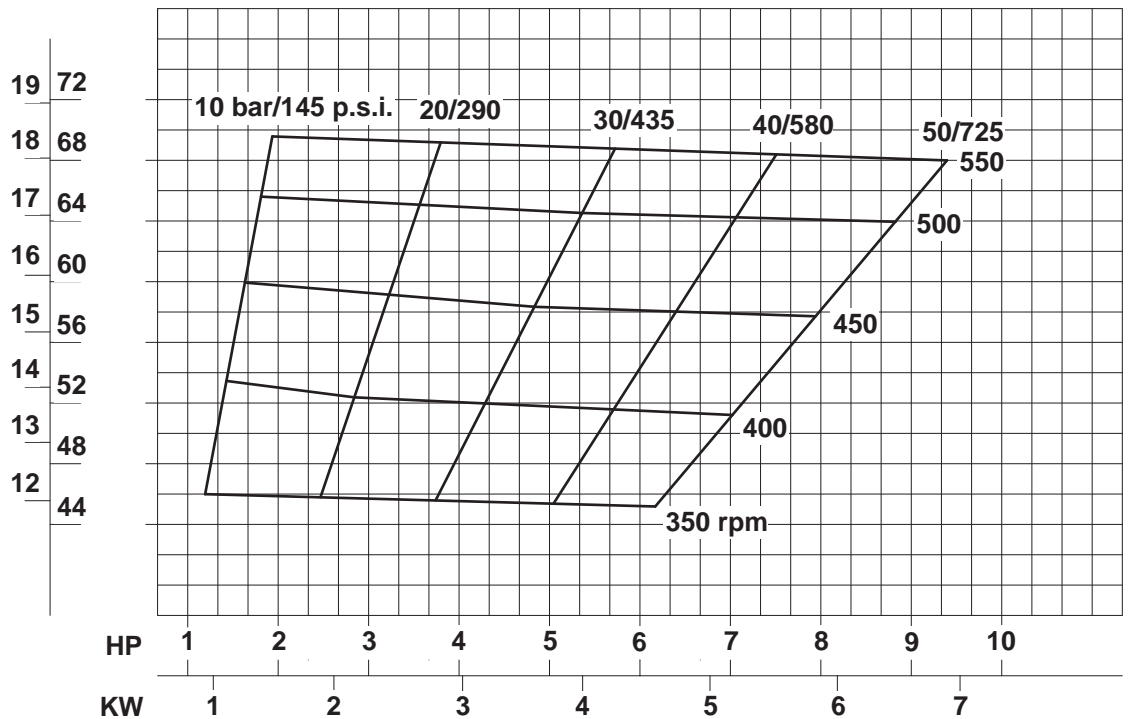

DATI INFORMATIVI

INDICATIVE DATA

DATOS INDICATIVOS

DONNÉES À TITRE D'INFORMATION

KENNDATEN UNVERBINDLICH



imovilli pompe S.r.l.

Via Masaccio, 1 Zona Industriale Mancasale - 42010 Reggio Emilia Italy Tel. +39 0522 516595 Fax +39 0522 514735

www.imovillipompe.it • e-mail: info@imovillipompe.it