

SHURflo

POWER TWIN

INSTALLATION AND OPERATION MANUAL

SHURflo offers various pump models for different applications. The information outlined by this manual is general and not specific to all Power Twin series pumps. Be certain the pumps' materials will be compatible with the fluid being pumped. Product Data Sheets outlining specific thermal limits, duty cycle, load, flow curves, and other technical information for a particular model are available. If unsure of the chemical compatibility with a given elastomer or the motors intended design, please call SHURflo for assistance.

CAUTION: "Intermittent Duty" is defined as: operated and/or frequently started within a period of time that would cause the motor to reach its maximum thermal limits. Once the maximum thermal limit is obtained, the motor must be allowed to return to ambient temperature before resuming operation.

CAUTION: **DO NOT** use to pump flammable liquids. Never operate the pump in an explosive environment. Arcing from the motor brushes, switch or excessive heat from an improperly cycled motor may cause an explosion.

CAUTION: **DO NOT** assume fluid compatibility. If the fluid is improperly matched to the pumps' elastomers, a leak may occur. Pumps used to transfer hazardous or hot (max. temperature 170° F [76° C] viton only) chemicals must be in a vented area to guard against the possibility of injury due to harmful or explosive liquid/vapors.

CAUTION: **DO NOT** operate the pump at pressures which cause the motor to exceed the amperes rating indicated on the name plate.

CAUTION: To prevent electrical shock, disconnect power before initiating any work. In the case of pump failure, the motor housing and/or the pumped fluid may carry voltage to components normally considered safe.

PRESSURE SWITCH OPERATION

The pressure switch reacts to outlet pressure, and interrupts power at the preset shut-off pressure indicated on the pump label. When outlet pressure drops below a predetermined limit (typically 15–20 psi [1–1.4 bar] less than the shut-off pressure), the switch will close and the pump will operate until the shut-off (high) pressure is achieved. The shut-off pressure is set to factory calibrated standards. See the motor label and Product Data Sheet for specific pump specifications.

CAUTION: Improper adjustment of the pressure switch may cause severe overload or premature failure. Refer to SHURflo Service Bulletin #1031 for the adjustment procedure. Failures due to improper adjustment of the pressure switch will not be covered under the limited warranty.

If the plumbing is restrictive or the flow rate is very low, the pump may re-pressurize the outlet faster than the fluid is being released causing rapid cycling (ON/OFF within 3 seconds). If the pump is subjected to rapid cycling during normal operation, or for infrequent periods, damage may occur. Applications which exhibit rapid cycling should have restrictions in the outlet minimized. If not feasible, consider a SHURflo accumulator as a pressurized liquid storage device.

MOUNTING

- Power Twin pumps are self priming. Horizontal and vertical prime vary depending on the fluid viscosity, tubing size and pump configuration. Refer to the Product Data Sheet for detailed model information.
- The pump should be located in an area that is dry and provides adequate ventilation. If mounted within an enclosure, provisions to cool the motor may be necessary.

CAUTION: **DO NOT** locate the motor near low temperature plastics or combustible materials. The surface temperature of the motor may exceed 212° F [100° C]. Refer to the Product Data Sheet.

- The pump may be mounted in any position. However, if mounting the pump vertically, the pump head with the pressure switch should be in the "UP" position so that in the event of a leak, fluid will not enter the switch.
- Secure the rubber feet with #8 hardware. **DO NOT** compress the feet, doing so will reduce their ability to isolate vibration/noise.

PLUMBING

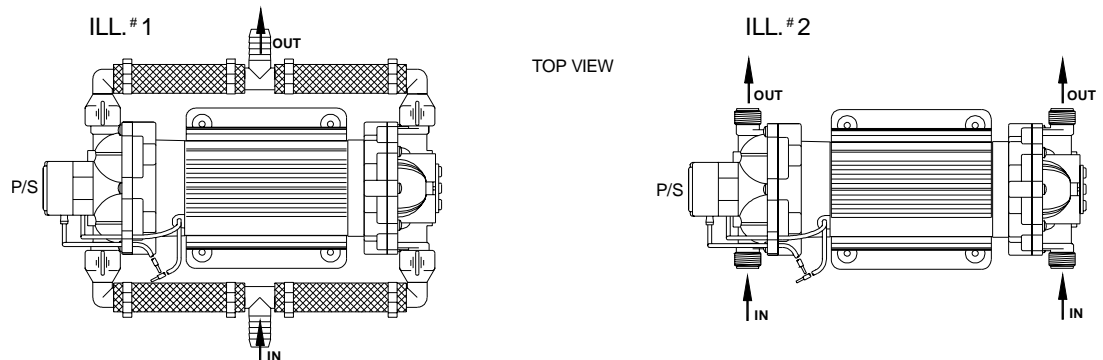

- Power Twins have two (each) inlet and outlet ports. They may be plumbed individually or together, depending upon the application.

CAUTION: **NEVER** stop or reduce output flow of the non-controlled (no P/S) pump head end (ill. #2) to pressures higher than indicated on motor nameplate. Failure of components will occur that are not covered under the standard SHURflo Limited Warranty.

- Maximum flow rating achieved through the inlet/outlet manifolds when $\frac{5}{8}$ " [15.8 mm] tubing is utilized. Optional SHURflo manifolds P/N 84-660-00 (ill. #1) are available.
- **Flexible** high-pressure tubing compatible with the fluid should be used to connect the inlet/ outlet ports. Flexible tubing should be at least 18 in. [46 cm] long to minimize stress on the fitting/ ports and reduce noise. Allow for the shortest possible tubing route and avoid sharp bends that may kink over time.

NOTE: Restrictions on the inlet may cause vacuum levels to reach the fluid vapor pressure, causing cavitation, degassing, vapor lock, loss of performance or shorter than expected diaphragm life. Positive static inlet pressure **must** not exceed 30 psi [2.1 bar] maximum.

- Confirm fluid chemical compatibility to the pump heads, manifolds, strainer(s).
- **½"-14 male threaded models:** Are intended to be used with SHURflo Swivel Barb Fittings which seal with an internal taper when **hand-tightened**. Standard ½"-14 fittings may be used when tightened to a maximum torque of 3.7 ft/lb (45 in/lb) [5•Nm].

NOTE: SHURflo does not recommend the use of metal fittings or rigid pipe to plumb the inlet/outlet ports. Standard plastic male and female threaded fittings can be acquired at commercial plumbing supply stores. SHURflo also distributes Swivel Barb Fittings and special fittings through its dealers (Form #07-010-0011).

CAUTION: Teflon tape or sealers may act as lubricant causing stripped threads or broken housings due to overtightening. Care should be used when applying sealers. Sealers may enter the pump inhibiting valve action, causing no prime or no shut-off. **Failure due to foreign debris is not covered under warranty.**

- Installation of a 50 mesh strainer (SHURflo P/N 252-3300) is recommended to prevent foreign debris from entering the pump.
- If a check valve is installed in the plumbing, it must have a cracking pressure of less than 2 psi [0.14 bar].

ELECTRICAL

CAUTION: Electrical wiring should be performed by a qualified electrician, in accordance with all local electrical codes.

- The pump should be on a dedicated (individual) circuit, controlled with a double pole switch (UL/C-UL certified) high the fuse ampere indicated by the pump motor label. Depending on distance of the power source from the pump and ampere load on the circuit, wire size may need to be heavier than indicated by the chart.
- Improper duty cycle and/or rapid start & stop conditions may result in premature motor failure due to excessive heat. Refer to the Product Data Sheet.
- For the pump to meet UL/C-UL requirements, the circuit **MUST be protected with a slow-blow fuse** (automotive type), UL/C-UL certified or equivalent circuit breaker as indicated on the motor label.

VOLTAGE	WIRE LEADS	WIRE SIZE	FUSE RATING
12 DC	Red (positive +) Black (negative –)	#12 max of 36 ft [11 M] #10 max of 57 ft [17 M] #8 max of 90 ft [27 M]	See pump motor label

CAUTION: Circuit protection is dependent on the individual application requirements. Failure to provide proper overload/thermal devices may result in a motor failure, which will not be covered under warranty.

SPECIFICATIONS

Voltage:	12 VDC
Maximum Amps:	18 amps
Pressure Switch:	OFF = 45 PSI [3.1 bar] ON = 25 PSI [1.7 bar] ±5 PSI [0.3 bar]
Duty Cycle:	Intermittent (only)
Maximum Starts/Minute:	20
Open Flow, H₂O:	7 GPM [26 lt/m] w/ ⁵ / ₈ " tubing, both heads
Ambient Temp. Range:	33°—120° F [0.5°—49° C]
Maximum Inlet Pressure:	30 PSI [2.0 bar]
Maximum Particulate Size:	Soft/Round 0.015" dia. [0.6mm]

SERVICE KITS

Kits are available to repair standard Power Twin series pumps. Repair kits include simple illustrated instructions allowing easy installation. To insure that the correct kit is received, the model number and all name plate data **must** be included with the order. Contact a SHURflo distributor or SHURflo directly to order the necessary repair kit.

RETURN POLICY

All Industrial pumps/products **must** be flushed of **any** chemical (ref. OSHA Section 1910.1200 (d)(e)(f)(g)(h)) and hazardous chemicals **must** be labeled/tagged before being shipped to SHURflo for service or warranty consideration. SHURflo reserves the right to request a Material Safety Data Sheet from the returnee for any pump/product it deems necessary. SHURflo reserves the right to "disposition as scrap" pumps/products returned which contain unknown fluids. SHURflo reserves the right to charge the returnee for any and all costs incurred for chemical testing and proper disposal of components containing unknown fluids. SHURflo requests this in order to protect the environment and personnel from the hazards of handling unknown fluids.

LIMITED WARRANTY PROCEDURE

SHURflo warrants Industrial Power Twin series pumps to be free from material and workmanship defects (under normal use and service) for a period of one (1) year from the date of manufacture.

The limited warranty will not apply to pumps that were improperly installed, misapplied, or are incompatible with components or liquid not manufactured by SHURflo. SHURflo will not warrant any pump which is physically damaged or modified outside the SHURflo factory.

All Industrial pumps/products **must** be flushed of **any** chemicals before shipping. All warranty considerations are governed by SHURflo's written Return Policy.

Returns are to be shipped postage pre-paid to either service center; SHURflo Garden Grove, CA or Elkhart, IN. SHURflo will not be liable for freight damage incurred during shipping. Package returns carefully.

Upon receiving a pump, it will be tested per SHURflo's test criteria. SHURflo's obligation under this warranty policy is limited to the repair or replacement of the unit. Pumps found not defective (under the terms of this limited warranty) are subject to charges to be paid by the returnee for the testing and packaging of "tested good" units.

No credit or labor allowances will be given to the returnee for pumps returned as defective. Warranty replacements will be shipped on a freight allowed basis. SHURflo reserves the right to choose the method of transportation.

This limited warranty is in lieu of all other warranties, expressed or implied, and no other person is authorized to give any other warranty or assume obligation or liability on SHURflo's behalf. SHURflo shall not be liable for any labor, damage or other expense, nor shall SHURflo be liable for any indirect, incidental or consequential damages of any kind incurred by the reason of the use or sale of any defective product or part. This limited warranty covers products distributed within the United States of America. Other world market areas should consult with their distributors for any deviation from this document.



*ISO Certified Facility

SHURflo®

SHURflo reserves the right to update specifications, prices, or make substitutions.

SHURflo ★

12650 Westminster Ave.
Santa Ana, CA 92706-2100
(800) 854-3218 (714) 554-7709
FAX (714) 554-4721

Shipping/UPS: 12650 Westminster Ave.
Garden Grove, CA 92843

SHURflo East

52748 Park Six Court
Elkhart, IN 46514-5427
(800) 762-8094 (219) 262-0478
FAX (219) 264-2169

<http://www.shurflo.com>

© 1999 Printed in USA

SHURflo Ltd.

Unit 5 Sterling Park
Gatwick Road, Crawley
West Sussex, RH10 2QT
United Kingdom
+44 1293 424000
FAX +44 1293 421880