

AT Series 75

Duplex Plunger Pump, Splined Shaft

FEATURES

- Aluminum manifold
- Die-cast, anodized aluminum, oil-bath crankcase
- Solid ceramic plungers with continuously lubricated packings
- The original InterPump unitized stainless steel K01 inlet and outlet valves
- Ideal for drain cleaning and jetting applications
- Duplex pulsing action for improved impacted cleaning
- Also available in "L" left-handed and aluminum manifold versions



SPECIFICATIONS

Pump Model	AT0033
Maximum Volume	7.93 GPM
Maximum Discharge Pressure	435 PSI
Maximum Pump Speed	650 RPM
Maximum Inlet Pressure	125 PSI
Bore	1.417 in. / 36 mm
Stroke (in./mm)	.945 / 24
Crankcase Oil Capacity	22 oz.
Maximum Fluid Temperature	165°F
Inlet Port Thread	3/4-14 BSPP-F
Discharge Port Thread	3/8-19 BSPP-F
Shaft Diameter	1-3/8" ASAE and 35mm solid
Weight	28 lbs.
Dimensions	12 x 9 x 7.3 in.

DIMENSIONAL DRAWING

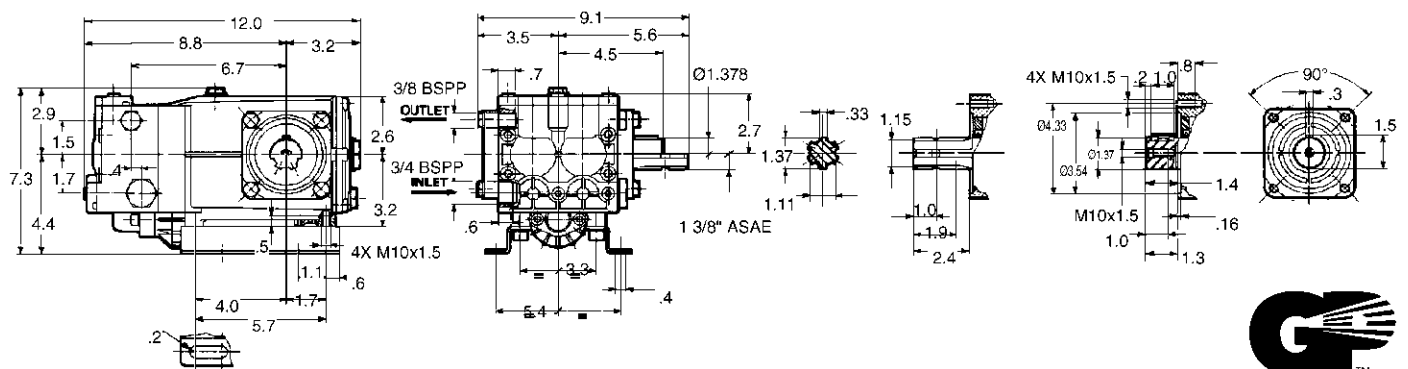

AT Series 75 – Duplex

GENERAL PUMP *A member of the Interpump Group*

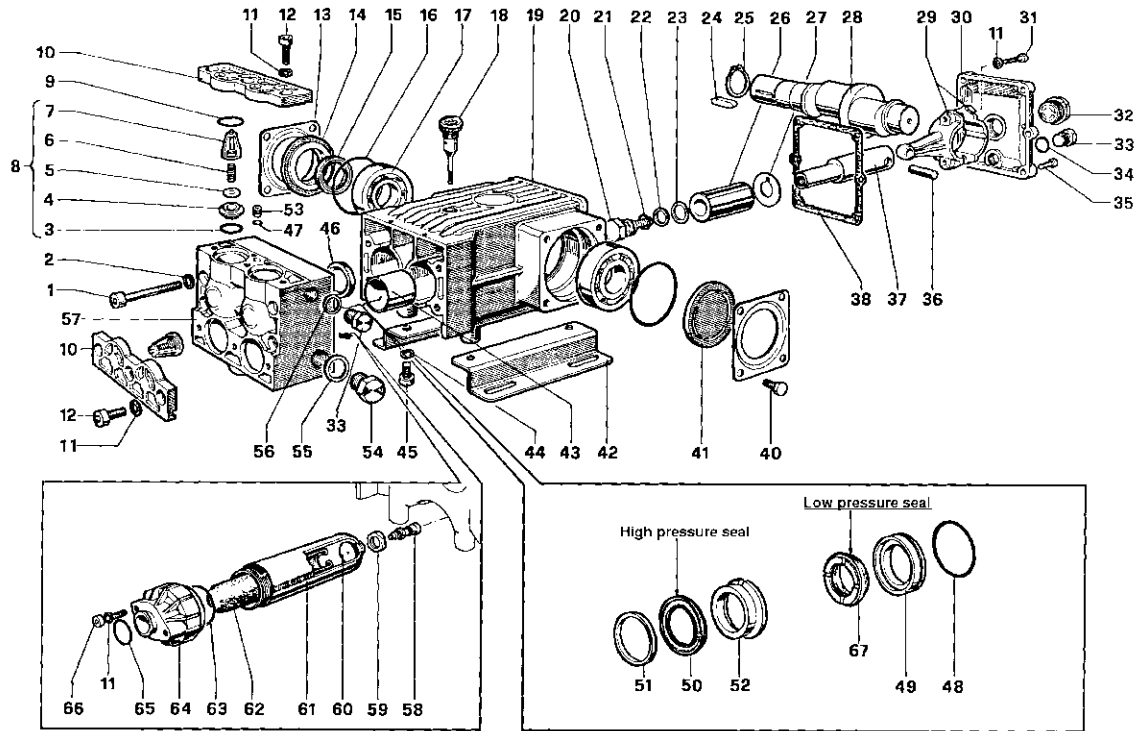

PARTS LIST

ITEM	PART NO.	DESCRIPTION	KIT	QTY.	ITEM	PART NO.	DESCRIPTION	KIT	QTY.	ITEM	PART NO.	DESCRIPTION	KIT	QTY.
1.	99.3787.00	Screw	4		23.	96.7555.00	Washer	74	2	45.	99.3644.00	Screw		4
2.	96.7104.00	Washer	4		24.	91.4878.00	Key		1	46.	90.1656.00	Oil Seal	37	2
3.	90.3859.00	O-Ring	62	4	25.	90.0695.00	Cir-Clip		1	47.	90.3576.00	O-Ring		1
4.	36.2017.66	Valve Seat	62	4	26.	69.0400.09	Plunger (36 mm)		2	48.	90.3885.00	O-Ring	39,40	2
5.	36.2018.76	Valve	62	4	27.	96.7565.00	Washer		2	49.	69.0802.70	Packing Retainer	39,40	2
6.	94.7394.00	Spring	62	4	28.	75.0208.35	Crankshaft, 1-3/8" x 35mm solid		1	50.	90.2820.00	Packing	38,39	2
7.	36.2008.51	Valve Guide	62	4		75.0203.35	Crankshaft, 35mm solid			51.	69.1002.93	Head Ring	39,41	2
8.	36.7060.01	Valve Unit	62	4		75.0205.35	Crankshaft, 1-3/8" ASAE			52.	69.2168.70	Intermed. Ring	39,42	2
9.	90.4055.00	O-Ring		4	29.	69.0300.01	Connecting Rod		2	53.	75.2203.70	Cap Screw		1
10.	75.2180.22	Valve Cover		2	30.	75.1600.22	Cover		1	54.	98.2265.00	Cap Screw		1
11.	96.7014.00	Washer		12	31.	99.3099.00	Screw		4	55.	96.7700.00	Washer		1
12.	99.3059.00	Screw		6	32.	97.5968.00	Oil Sight Gauge		1	56.	96.7380.00	Washer		1
13.	68.1500.74	Crankcase Cover		2	33.	98.2100.00	Cap Screw		2	57.	75.1200.22	Manifold		1
14.	69.2115.51	Spacer		1	34.	90.3833.00	O-Ring		1	58.	98.8650.00	Air Valve		1
15.	90.1672.00	Oil Seal		32	35.	99.1867.00	Screw		6	59.	92.2562.00	Nut		1
16.	90.4131.00	O-Ring		2	36.	97.7398.00	Pin		2	60.	75.2105.70	Diaphragm Screw		1
17.	91.8470.00	Bearing		2	37.	69.0500.22	Plunger Guide		2	61.	75.1800.89	Cover		1
18.	98.2106.00	Oil Dipstick		1	38.	75.2119.84	Gasket		1	62.	75.1700.47	Diaphragm		1
19.	75.0100.22	Crankcase		1	40.	99.3636.00	Screw		8	63.	90.4077.00	O-Ring		1
20.	69.2195.66	Plunger Screw		74	41.	69.2116.51	Spacer		1	64.	75.1900.64	End Cover		1
21.	90.3841.00	O-Ring		74	42.	47.2000.74	Foot		2	65.	90.4041.00	O-Ring		1
22.	90.5107.00	Anti-Ext. Ring		74	43.	90.9162.00	Bushing		2	66.	99.3084.00	Screw		2
					44.	96.7106.00	Washer		4	67.	90.2823.00	Seal, Low Press., 36mm	38,39	2

REPAIR KITS

KIT NO.	32	37	38	39	40	41	42	62	74
ITEM NO.s INCLUDED IN KIT	15	46	50, 67	48, 49, 50, 51, 52, 67	48, 49	51	52	3, 4, 5, 6, 7 (8)	20, 21, 22, 23
NUMBER OF ASSEMBLIES IN KIT	2	3	3	1/2	3	6	3	6	3
NUMBER OF CYLINDERS KIT WILL SERVICE	-	3	3	1	3	3	3	3	3

TORQUE SPECS*

Position	Ft.-lbs.
1	29.4
12	14.7
20	29.4
31	14.7
32	13.2
33	29.4
35	7.3
40	29.4
45	29.4
54	51.5
66	14.7

*Decrease torque by 20% if threads are lubricated.

