

APS 145



POMPE A MEMBRANA AD ALTA PRESSIONE
HIGH PRESSURE DIAPHRAGM PUMPS
POMPES A MEMBRANE A HAUTE PRESSION
BOMBAS A MEMBRANA DE ALTA PRESSION
HOCHDRUCK-MEMBRANPUMPEN



Configurazione: 4 membrane in NBR (Desmopan® e Viton a richiesta). Parti a contatto con il liquido: alluminio anodizzato. Di serie: accumulatore di pressione e valvola di sicurezza. A richiesta: protezione p.d.f..

Configuration: 4 diaphragms in NBR (Desmopan® and Viton available on request). Parts in contact with spray liquid: anodized aluminium. Standard: pressure accumulator and safety valve. On request: PTO protection.

Configuration : 4 membranes en NBR (Desmopan® et Viton à la demande). Parties au contact du liquide : aluminium anodisé. De série : accumulateur de pression et soupape de sécurité. À la demande : protection prise de force.

Configuración: 4 membranas en NBR (Desmopan® y Viton bajo pedido). Partes en contacto con el líquido: aluminio anodizado. De serie: acumulador de presión y válvula de seguridad. Bajo pedido: protección toma de fuerza (t.d.f.).

Konfigurierung: 4 Membranen aus NBR (Desmopan® und Viton auf Wunsch). Teile im Kontakt mit der Flüssigkeit: eloxiertes Aluminium. Serienmäßig: Druckspeicher und Sicherheitsventil. Auf Wunsch: Zapfwellenschutz.

APS 145

	0 bar - 0 p.s.i				20 bar - 290 p.s.i				30 bar - 435 p.s.i				40 bar - 580 p.s.i				50 bar - 725 p.s.i											
	RPM		l/min		U.S.g.p.m.		HP		kW		l/min		U.S.g.p.m.		HP		kW		l/min		U.S.g.p.m.		HP		kW		kg	lb
400	112	29,6	1,1	0,8	109	28,8	6,7	4,9	108	28,5	8,7	6,4	107	28,2	11,0	8,1	106	27,9	13,4	9,9								
450	125	33,0	1,3	1,0	122	32,3	6,9	5,1	121	32,0	9,7	7,1	120	31,8	12,4	9,1	119	31,5	15,0	11,0								
500	138	36,5	1,4	1,0	135	35,7	7,6	5,6	134	35,4	10,8	7,9	133	35,1	13,7	10,1	132	34,8	16,6	12,2								
550	149	39,2	1,5	1,1	145	38,4	8,2	6,0	144	38,1	11,6	8,5	143	37,7	14,7	10,8	142	37,5	18,0	13,2								

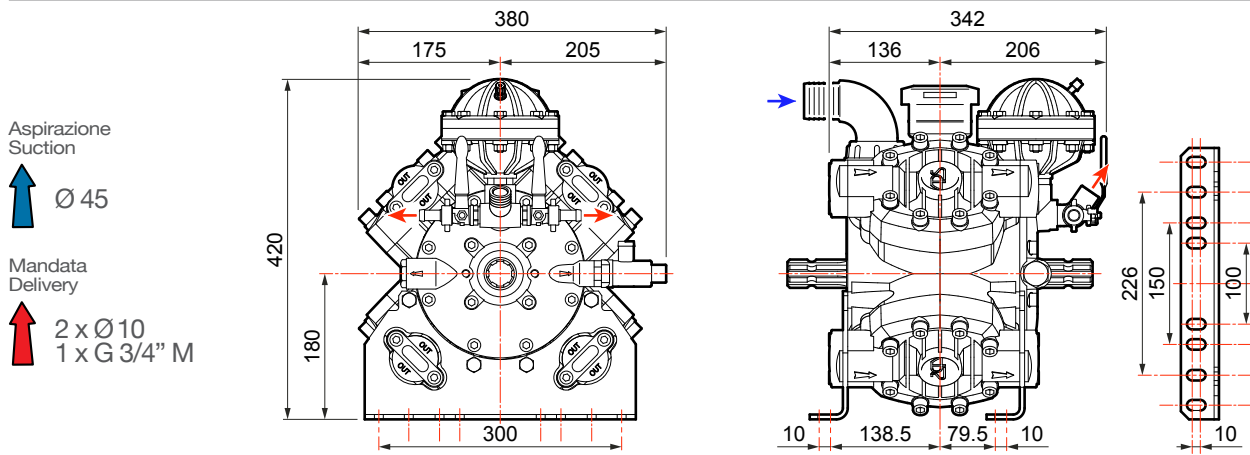

VERSIONI STANDARD · STANDARD VERSIONS · VERSIONS STANDARD · VERSIONES ESTÁNDAR · STANDARDAUSFÜHRUNGEN
Versioni derivate · Versions adapted · Versions dérivées · Versiones derivadas · Von der Standardversion abgeleitete Ausführungen

A



Albero passante
Through shaft
Arbre traversant
Cigüeñal pasante
Durchgangswelle

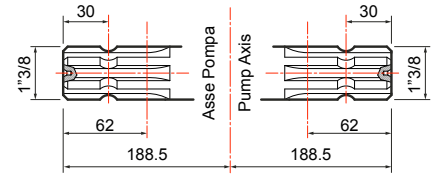
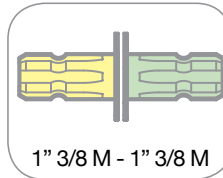

1



Flangiata a motore idraulico
Flanged to hydraulic motor
Bridée à un moteur hydraulique
Conexión con brida a motor hidráulico
An Hydraulikmotor geflanscht

2



Flangiata a pompa idraulica
Flanged to hydraulic pump
Bridée à une pompe hydraulique
Conexión con brida a bomba hidráulica
An Hydraulikpumpe geflanscht

B



Albero passante
Through shaft
Arbre traversant
Cigüeñal pasante
Durchgangswelle

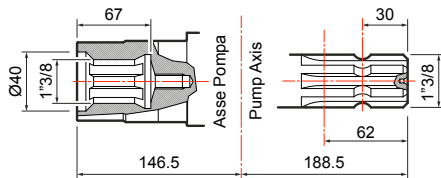
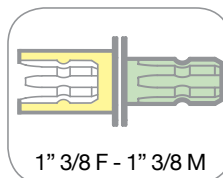

1



Flangiata a motore idraulico
Flanged to hydraulic motor
Bridée à un moteur hydraulique
Conexión con brida a motor hidráulico
An Hydraulikmotor geflanscht

2



Flangiata a pompa idraulica
Flanged to hydraulic pump
Bridée à une pompe hydraulique
Conexión con brida a bomba hidráulica
An Hydraulikpumpe geflanscht

3



Flangiata a moltiplicatore
Coupled to overgearbox
Bridée à un multiplicateur
Conexión con brida a moltiplicador
An Übersetzungsgetriebe geflanscht

4



Kit Puleggia
Pulley kit
Kit Poulie
Kit Polea
Riemenscheibenkit

