

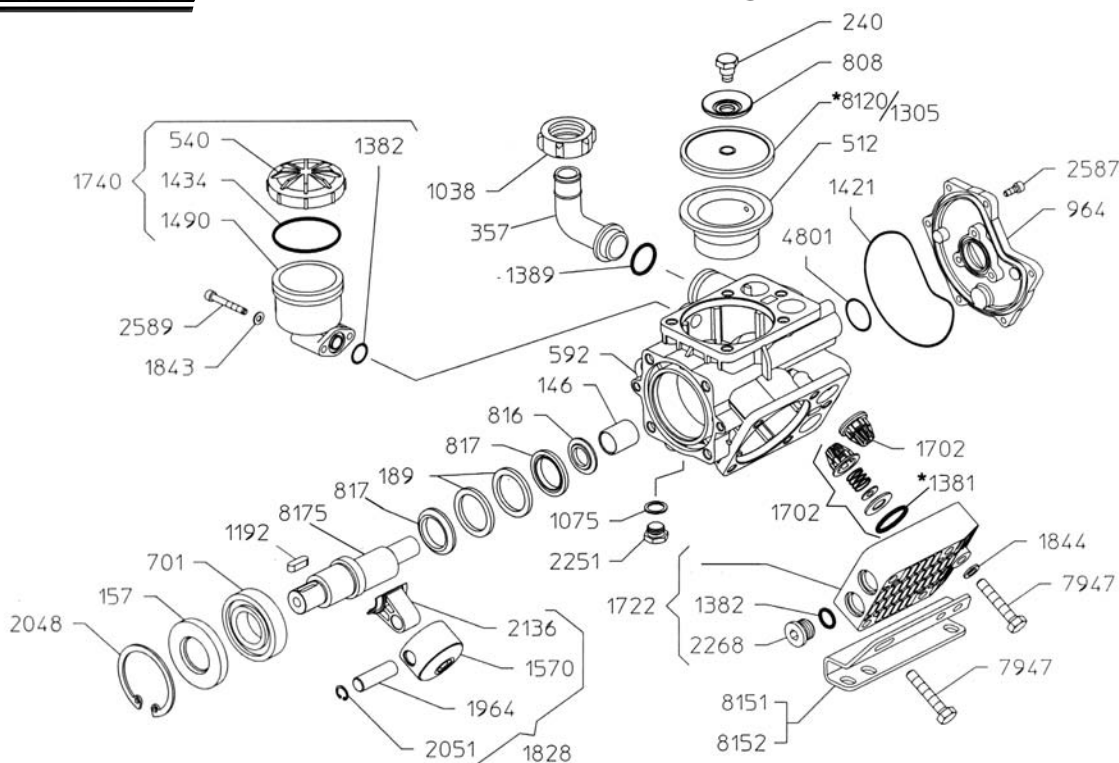

KAPPA-33/43/53

Exploded View Diagram and Parts List



KAPPA-33/43/53

KAPPA-33/43/53 PUMPS
 Require **20 oz.**
UDOR LUBE,
 or SAE 30W
 Non-detergent Oil

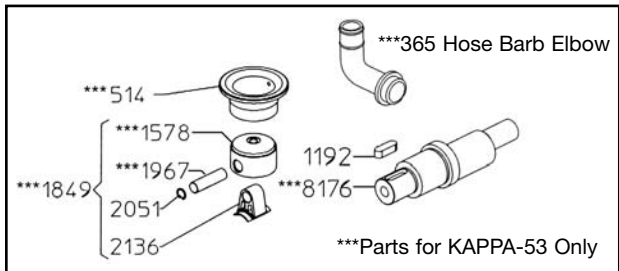
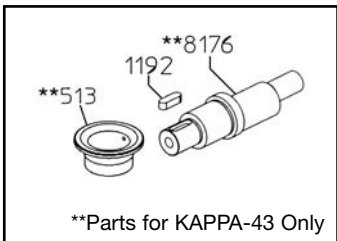

REF#	PART#	DESCRIPTION	QTY	REF#	PART#	DESCRIPTION	QTY
146	02-0006.14	Bearing	1	1702	02-6006.01	Valve Assembly	6
157	02-0007.05	Seal	1	1722	02-6017.13	Head Assembly	3
189	02-0001.11	Retaining Ring	2	1740	02-6033.01	Oil Reservoir Assembly	1
240	02-0102.04	Diaphragm Bolt	3	1828	02-6015.45	Piston & Rod Assembly (KAPPA-33/43)	3
357	02-0202.18	Suction Elbow	1	1843	02-1403.07	Washer	2
***365	02-0202.52	Suction Elbow (KAPPA-53)	1	1844	02-1403.09	Washer	11
512	02-0206.42	Piston Sleeve (KAPPA-33)	3	***1849	02-6015.46	Piston & Rod Assembly (KAPPA-53)	3
**513	02-0206.41	Piston Sleeve (KAPPA-43)	3	1964	02-1502.03	Connecting Rod Pin (KAPPA-33/43)	3
***514	02-0206.43	Piston Sleeve (KAPPA-53)	3	***1967	02-1502.07	Connecting Rod Pin (KAPPA-53)	3
540	02-0208.98	Oil Reservoir Cap	1	2048	02-1506.07	Snap Ring	1
592	02-0209.73	Crankcase	1	2051	02-1506.15	Snap Ring	6
701	02-0214.05	Bearing	1	2136	02-1519.28	Connecting Rod (KAPPA-33/43/53)	3
808	02-0301.43	Retaining Washer	3	2251	02-1603.02	Plug	1
816	02-0301.54	Spacer	1	2268	02-1603.32	Head Plug	6
817	02-0302.66	Spacer	2	2587	02-1805.20	Bolt	6
964	02-0501.E2	Body Flange	1	2589	02-1805.31	Bolt	2
1038	02-0604.18	Barb Nut	1	4801	02-1101.C3	O-Ring	1
1075	02-0605.43	Gasket	1	7947	02-1804.21	Head Bolt	15
1192	02-0801.02	Shaft Key	1	*8120	02-0903.50	Piston Diaphragm (DESMOPAN)	3
1305	02-0903.43	Piston Diaphragm (BUNA-N) optional	3	8151	02-1202.63	Mounting Rail - Right Side	1
*1381	02-1101.27	O-Ring	6	8152	02-1202.64	Mounting Rail - Left Side	1
1382	02-1101.29	O-Ring	7	8175	02-0002.B8	Crankshaft (KAPPA-33)	1
1389	02-1101.41	O-Ring	1	**8176	02-0002.B7	Crankshaft (KAPPA-43/53)	1
1421	02-1101.88	O-Ring	1				
1434	02-1101.D1	O-Ring	1				
1490	02-1203.27	Oil Reservoir	1				
1570	02-1205.07	Piston (KAPPA-33/43)	3				
***1578	02-1205.18	Piston (KAPPA-53)	3				

*Parts included in Diaphragm Repair Kit - #8700.45
 Diaphragm Repair Kit also available in BUNA-N - #8700.46
 **Parts for KAPPA-43 only.
 ***Parts for KAPPA-53 only.



KAPPA-33/43/53

Medium Pressure Diaphragm Pump

KAPPA-33/43/53 3-cylinder, medium pressure diaphragm pumps are excellent choices for various horticulture, agricultural, lawn care, nursery, pest control and turf spraying applications. They are also effectively used in other applications such as aircraft de-icing, hydrostatic testing and cleaning. The KAPPA-33/43/53 pumps come standard with mounting rails and a 25mm solid keyed shaft.

KAPPA-33/43/53 pumps are constructed of anodized aluminum with anodized aluminum and stainless steel liquid handling parts. Control valve and pressure gauge are standard on all models.

Drive options include 5071.75 4-6.5 HP gear reduction.

For applications not listed, please consult UDOR U.S.A.

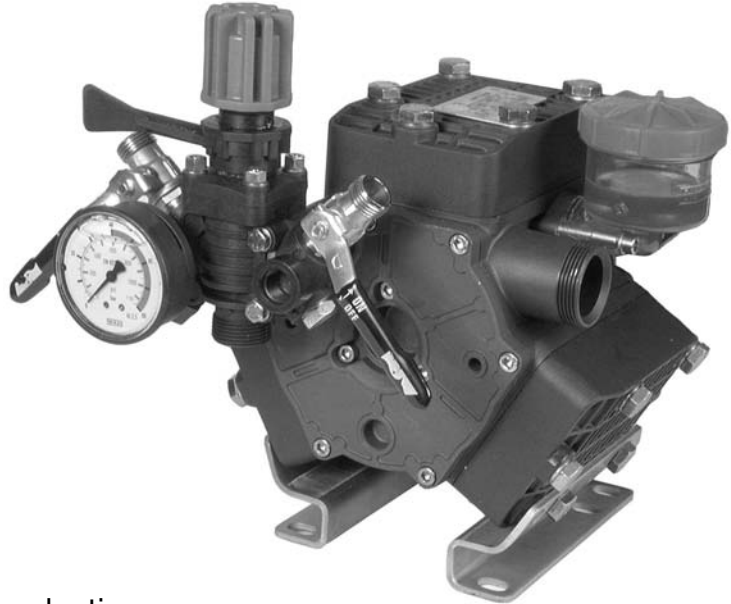

SPECIFICATIONS

Maximum Flow	
KAPPA-33	8.5 GPM
KAPPA-43	10.5 GPM
KAPPA-53	12.5 GPM
Maximum Pressure	560 PSI
Maximum RPM	540 RPM
Maximum Temperature	140° F
Inlet Port (Hose Barb) K-33 & 43	1"
* Inlet Port Hose Barb K-53	1-1/4"
Outlet Ports (Hose Barb, Ball Valve Controlled)	1/2" (2)
Bypass (Hose Barb)	3/4"
Dimensions	L-9.25" x W-11" x H-10"
Weight	29 lbs.
Diaphragm Material	
Standard	DESMOPAN
Optional	BUNA-N

NOTE - Protect pumps from freezing. If freezing conditions exist, flush pump and system with a 50/50 mixture of antifreeze and water.